

**OPERATOR'S MANUAL  
FOR  
IMPROVED RIBBON  
BRIDGE (IRB)**

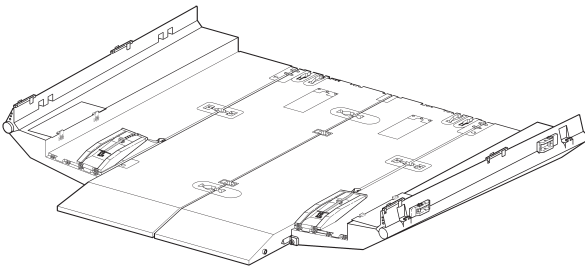

**RAMP BAY M16  
NSN 5420-01-470-5825  
P/N 12478918 EIC: XMT**

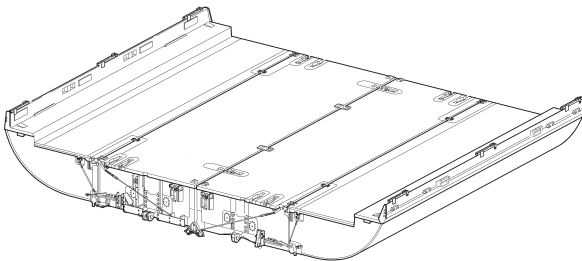

**INTERIOR BAY M17  
NSN 5420-01-470-5824  
P/N 12478919 EIC: XMS**

HOW TO USE THIS MANUAL

GENERAL INFORMATION

DESCRIPTION AND  
THEORY OF OPERATION

OPERATING INSTRUCTIONS

OPERATOR'S  
TROUBLESHOOTING

OPERATOR'S MAINTENANCE

REFERENCES

COMPONENTS OF END  
ITEM (COEI) AND BASIC ISSUE  
ITEMS (BII) LISTS

ADDITIONAL AUTHORIZATION  
LIST (AAL)

EXPENDABLE/DURABLE  
SUPPLIES AND MATERIALS LIST

DISTRIBUTION STATEMENT A. Approved for public release; distribution is unlimited.

HEADQUARTERS, DEPARTMENT OF THE ARMY

APRIL 2003

TM 5-5420-278-10

**HEADQUARTERS,  
DEPARTMENT OF THE ARMY  
WASHINGTON, D.C., 8 April 2003**

**TECHNICAL MANUAL  
OPERATOR'S MANUAL  
FOR  
IMPROVED RIBBON  
BRIDGE (IRB)**

<b>IRB</b>	<b>MODEL</b>	<b>NSN</b>	<b>P/N</b>	<b>EIC</b>
Ramp Bay	M16	5420-01-470-5825	12478918	XMT
Interior Bay	M17	5420-01-470-5824	12478919	XMS

**REPORTING ERRORS AND RECOMMENDING IMPROVEMENTS**

You can help improve this publication. If you find any mistakes or if you know of a way to improve the procedures, please let us know. Submit your DA Form 2028 (Recommended Changes to Publications and Blank Forms), through the Internet, on the Army Electronic Product Support (AEPS) website. The Internet address is <http://aeps.ria.army.mil>. If you need a password, scroll down and click on "ACCESS REQUEST FORM." The DA Form 2028 is located in the ONLINE FORMS PROCESSING section of the AEPS. Fill out the form and click on SUBMIT. Using this form on the AEPS will enable us to respond quicker to your comments and better manage the DA Form 2028 program. You may also mail, fax or E-mail your letter or DA Form 2028 direct to: AMSTA-LC-CI Tech Pubs, TACOM-RI, 1 Rock Island Arsenal, Rock Island, IL 61299-7630. The E-mail address is [TACOM-TECH-PUBS@ria.army.mil](mailto:TACOM-TECH-PUBS@ria.army.mil). The fax number is DSN 793-0726 or Commercial (309) 782-0726. (Marine Corps) Submit NAVMC 10722 to Commander Code 835-2, Marine Corps Logistic Base, 814 Radford Boulevard, Albany, GA 31704-1128.

**DISTRIBUTION STATEMENT A** —Approved for public release; distribution is unlimited.

**TABLE OF CONTENTS**

	<u>WP Sequence No.</u>
WARNING SUMMARY .....	a
HOW TO USE THIS MANUAL .....	v
GENERAL INFORMATION .....	0001 00
CHAPTER 1 DESCRIPTION AND THEORY OF OPERATION	
Section I. Equipment Description and Data .....	0002 00
II. Theory of Operation .....	0004 00
CHAPTER 2 OPERATING INSTRUCTIONS	
Section I. Description and Use of Operator's Controls and Indicators .....	0006 00
II. Operator's Preventive Maintenance Checks and Services (PMCS) .....	0012 00
III. Operation Under Usual Conditions .....	0017 00
IV. Operation Under Unusual Conditions .....	0045 00
V. Operation of Special Purpose Kits .....	0052 00
CHAPTER 3 OPERATOR'S TROUBLESHOOTING	
Section I. Introduction to Troubleshooting .....	0054 00
II. Operator's Troubleshooting Procedures .....	0056 00
CHAPTER 4 OPERATOR MAINTENANCE INSTRUCTIONS	
Section I. Service Upon Receipt .....	0061 00
II. Lubrication Instructions .....	0063 00
III. General Maintenance Procedures .....	0066 00
IV. Operator Maintenance Procedures .....	0067 00
CHAPTER 5 SUPPORTING INFORMATION	
References .....	0069 00
Components of End Item (COEI) and Basic Issue Items (BII) Lists .....	0070 00
Additional Authorization List (AAL) .....	0071 00
Expendable/Durable Supplies and Materials List .....	0072 00
GLOSSARY .....	Glossary 1
INDEX .....	INDEX 1

## HOW TO USE THIS MANUAL

### ABOUT YOUR MANUAL

Equipment operators shall familiarize themselves with the format and use of this Technical Manual (TM) prior to equipment operation or performing routine maintenance. Learning how to use this manual will enable personnel to quickly locate information, gain proper knowledge of the equipment, and shorten the time necessary to complete the required procedure.

Features of this TM are:

- a. **Work Package Format** –This TM is organized in Work Packages (WP). Each WP is an independent, stand-alone data unit. The subject title of each WP is assigned a six-digit sequence number. The first four digits of the sequence number identify the WP, and WPs are positioned in the TM in numerical order using the same four digits. The fifth and sixth digits of the sequence number are reserved for numbering WPs added to the TM as part of a future revision. Each WP is page numbered consecutively, after the sequence number, at the bottom of each page. A WP may contain as many as thirty pages.
- b. **Text Design** –WP titles and sequence numbers are listed in the Table of Contents, at the beginning of each chapter and section, and in the index. The index is organized by subject, in alphabetical order, with WP sequence and page numbers provided. Task steps and figure(s) are located side-by-side on facing pages. Lubrication instructions are included with operator's Preventive Maintenance Checks and Services (PMCS).
- c. **Use of Illustrations** –Illustrations are presented with exploded views, cut-away views, and individual callouts for identification of components and parts. Callouts are numbered in clockwise order starting at the 11 o'clock position.
- d. **Nomenclature Cross-Reference List** –Nomenclature (names given to individual parts and components) used in this manual may differ from the common terminology currently used in the field. A list of TM nomenclature and common nomenclature is provided in the Glossary of this manual.

### HOW TO USE YOUR MANUAL

The format of this manual is designed to make accessing information quick and easy. The following example is intended as a guide and should be reviewed and put to memory before attempting to use this manual. If you have any questions after reviewing the following example, don't hesitate to ask your supervisor.

**PROBLEM:** You receive a report that states the IRB-I inner ponton leaks water.

**SOLUTION:** You must find information on ponton leaks in the IRB manual and perform the necessary troubleshooting tasks to solve the problem.

## HOW TO USE THIS MANUAL (Contd)

### NOTE

If you are trying to find information by subject, a subject index can be found at the back of the book.

1. Go to Table of Contents and find Chapter 3. You will find two sections in Chapter 3. Turn to WP 0054 00, Section I, Introduction to Troubleshooting Table of Contents first, then proceed to WP 0055 00 and read the information under "General" in Introduction to Troubleshooting.
2. Go to WP 0056 00, Section II, Operator's Troubleshooting Procedures Table of Contents to find the work package number for the appropriate symptom index. In this case, you have a mechanical problem. Turn to WP 0057 00, Mechanical Troubleshooting Symptom Index, and look down the list of malfunctions until you identify the heading for ponton leaking.
3. Go to malfunction no. 5, WP 0058 00, Inner or Outer Ponton Leaking, and follow the steps and substeps listed. As you perform step 1b, you discover there are no seals on the bilge plugs. Now you must notify unit maintenance as instructed.
4. When maintenance is allocated at operator's level, you must perform and complete all instructions as outlined.

**GENERAL INFORMATION  
FOR  
IMPROVED RIBBON BRIDGE (IRB)**

General Information .....WP 0001 00

## GENERAL INFORMATION

### SCOPE

This TM contains operator's level instructions for the operation and servicing of the Improved Ribbon Bridge (IRB), Common Bridge Transporter (CBT), and the Bridge Adapter Pallet (BAP). Operation includes launching, construction of bridge, rafting, and retrieval. Servicing includes lubrication, Preventive Maintenance Checks and Service (PMCS), operator troubleshooting, and operator maintenance as allocated by the Maintenance Allocation Chart (MAC). Maintenance and repair of IRB, BAP, and CBT components are allocated for unit, direct support, and general support maintenance and are not authorized at the operator's level.

**a. Type of Manual:** Operator/crew.

**b. Model Number and Equipment Names:** The IRB consists of two major components; the Ramp Bay M16 and the Interior Bay M17.

**c. Purpose of Equipment:** To provide a means to support military vehicles, equipment, and personnel across large, nonfordable streams or rivers in a minimum amount of time, thereby increasing the strategic options for a military convoy. The IRB facilitates U.S. Army task force defensive and offensive maneuvers by supporting operations across wet gap barriers to rapidly cross vehicles. Refer to Table 3, WP 0036 00-2, for IRB MLC ratings.

### **WARNING**

The M812 and M945 vehicles are overloaded when carrying the IRB bridge and ramp modules. While limited testing was successful, vehicle reliability-related performance as well as vehicle dynamic performance can be adversely affected by the overload on the vehicle. It is recommended if the M812 and M945 are used to transport the IRB, operations should be limited to reasonably level terrain and slow speeds. Failure to comply may result in damage to equipment or possible injury or death to personnel.

### **NOTE**

When connecting IFB bays with IRB bays, refer to TM 5-5420-209-12 for operating instructions unique to IFB bays.

**d. Special Inclusions:** For operation and maintenance of the basic M977 HEMTT truck chassis, refer to TM 9-2320-279-10, -12, and -20. For operation of the Bridge Erection Boat (BEB), refer to TM 5-1940-277-10. For operation of the Improved Boat Cradle (IBC), refer to TM 5-5420-277-14&P. For river crossing instructions, refer to FM 90-13, River Crossing Operations. For training instructions, refer to TC 5-210, Military Float Bridging Equipment and Field Manual 5-34, Engineer Field Data, chapter 7, Bridging. For river crossing instructions, refer to FM 90-13, River Crossing Operations.

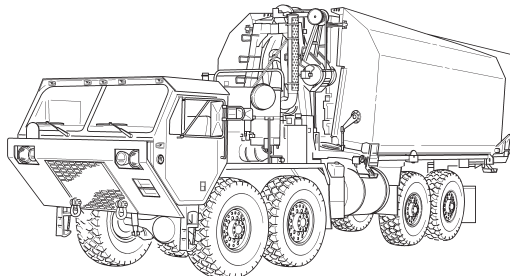

**RAMP BAY M16 ON CBT, TYPICAL**  
0001 00-1

**GENERAL INFORMATION (Contd)**

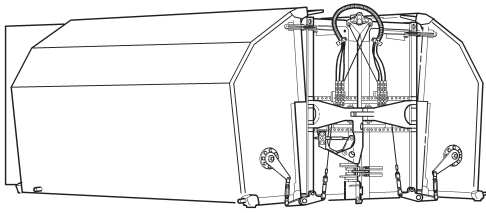

**FOLDED**

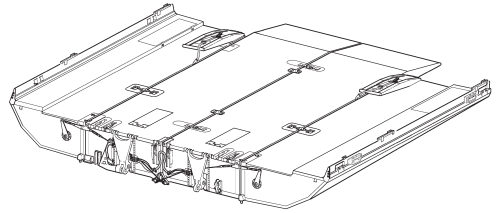

**UNFOLDED**

**RAMP BAY M16**

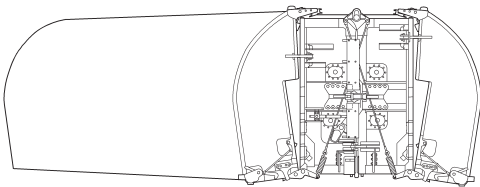

**FOLDED**

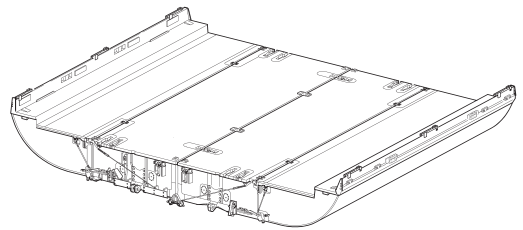

**UNFOLDED**

**INTERIOR BAY M17**

**GENERAL INFORMATION (Contd)**

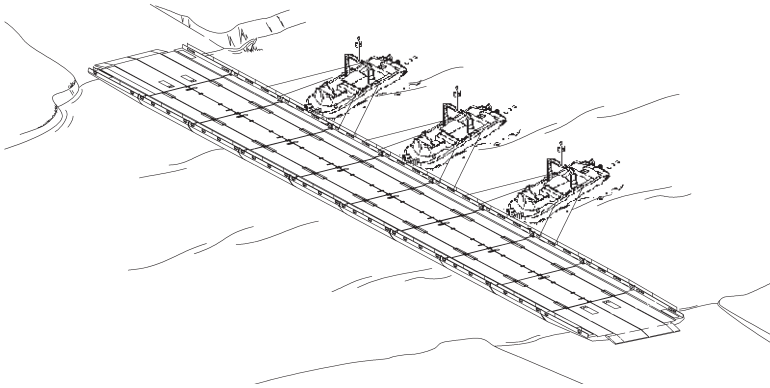

**TYPICAL BRIDGE BOAT ANCHORING**

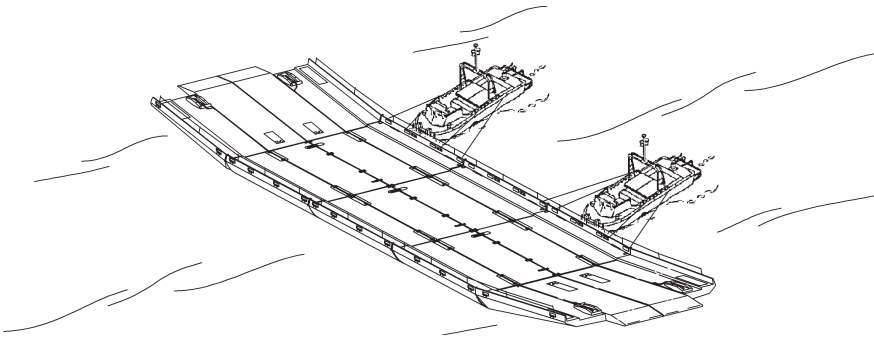

**TYPICAL CONVENTIONAL RAFTING**

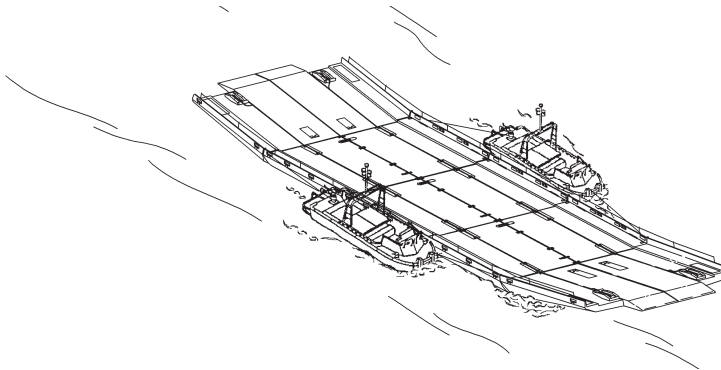

**TYPICAL LONGITUDINAL RAFTING**